

ALTUNTOP

ALTUNTOP

ROTARY RACK OVEN - FRONT BURNER
DÖNER ARABALI FIRIN - ÖNDEN BRÜLÖR

B2B

TECHNICAL TABLE

	ATDFY 150	ATDFY 300
Tepsi Sayısı - Number of Trays(pcs) Nombre De Plateaux (quantité)-Количество противней (шт)	16-18	16-18
Tepsi Ölçüleri - Tray Dimensions (mm) Taille du plateau - Размеры противней (мм)	600x800 800x800	800x1000
Genişlik - Width (mm) Largeur - Ширина (мм)	2170	2270
Derinlik - Depth (mm) Longueur - Глубина (мм)	1570	1630
Araba Sayısı - Number of Trolley Nombre de chariot - Количество тележек	1	1
Maksimum Derinlik - Max.Depth (mm) Max.Longueur - Макс. глубина (мм)	1980	2040
Maksimum Yükseklik - Max.Height H(mm) Max.Hauteur - Макс. высота (мм)	2770	2770
Araba Giriş Aralığı - Trolley Transition Range (mm) Gamme D'entrée Trolley - Ширина дверного проема(мм)	1060	1060
Pişirme Alanı - Baking Area (m²) Surface De Cuisson - Площадь выпечки (m²)	8.64	14.40
Tavalar Arası Mesafe - Space Between the Trays (mm) Distance Entre les Plateaux - Расстояние между противнями (мм)	85-95	85-95
Motor Gücü - Motor Power (kw) Puissance Du Moteur (kw) - Электрическая мощность (кВт)	3 kW	3 kW
Brülör Modeli - Burner Model Modèle de brûleur - Модель горелки	RIELLO FS15-G10	RIELLO FS20 / G20
Firin Ağırlığı - Weight (kg) Poids(kg) - Вес (кг)	1720	1870
Kontrol Sistemi - Control System Système De Contrôle - Панель управления	Manuel Dijital - Manual Digital - ManualDigitale - Ручное / цифровое	
Enerji Kaynakları - Energy Source Source D'énergie - Источники энергии	Doğalgaz,LPG, Motorin,Fuel Oil, Elektrik Natural Gas,LPG,Diesel,Fuel,Fuel Oil,Electricity Gaz,Diesel,Electrique,A bois Природный газ, дизельное топливо, мазут, твердое топливо, электричество	

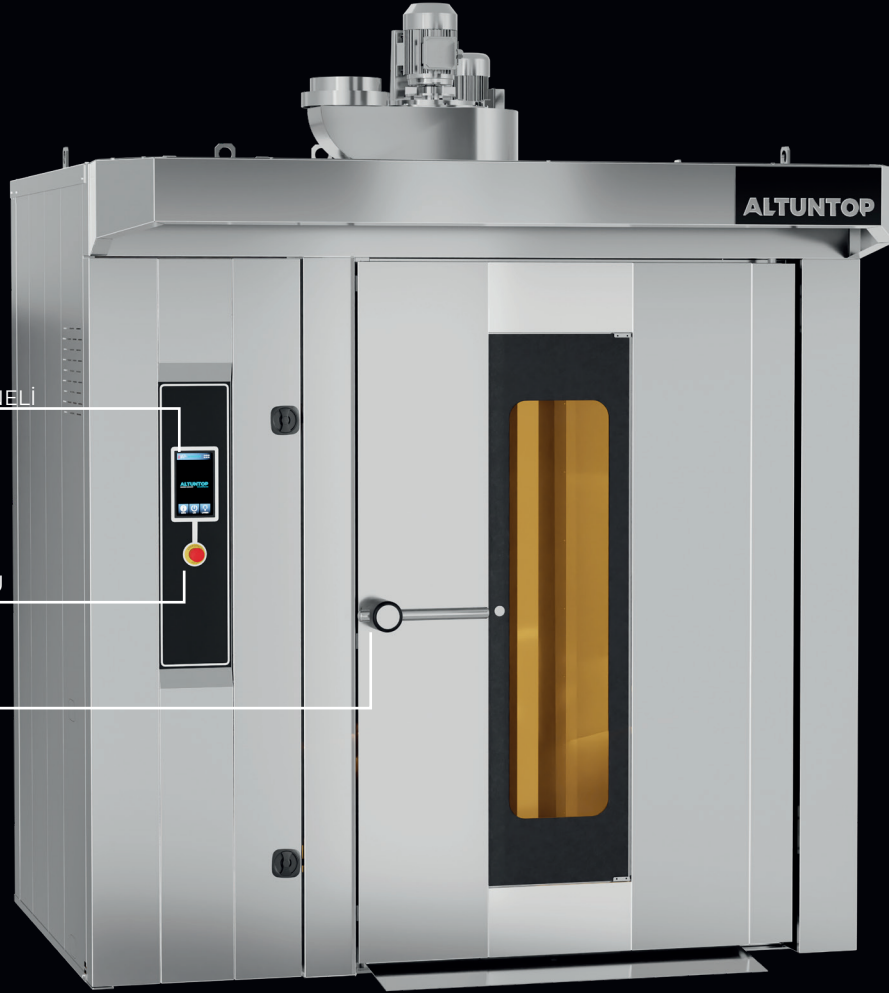

DİJİTAL KONRTOL PANELİ

ACİL STOP BUTONU

KAPI KOLU

REDÜKTÖR

0.55 kW / 1500 d/dk (3.5 devir)

BUĞU FAN MOTORU
(0.75 kW / 1500 d/dk)

SU GİRİŞİ: 1/2"

SENSÖR

CEHENNEMLİK BACASI
● 195

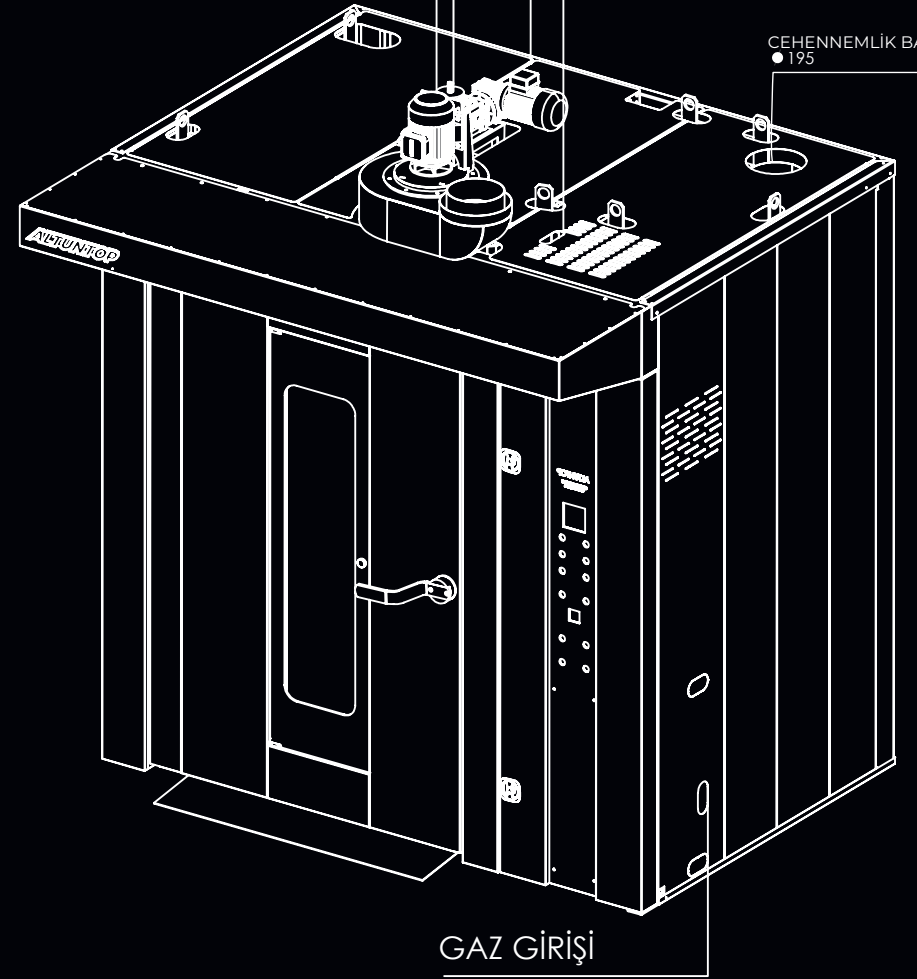

GAZ GİRİŞİ

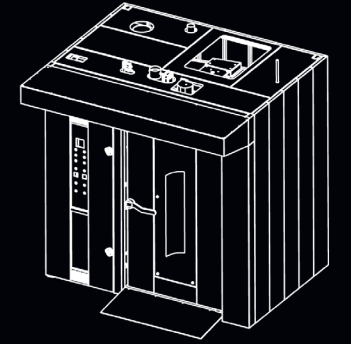
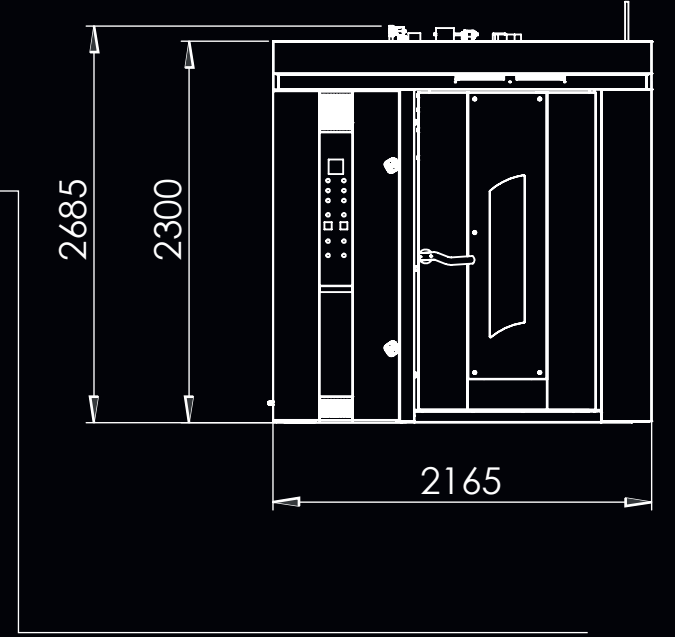
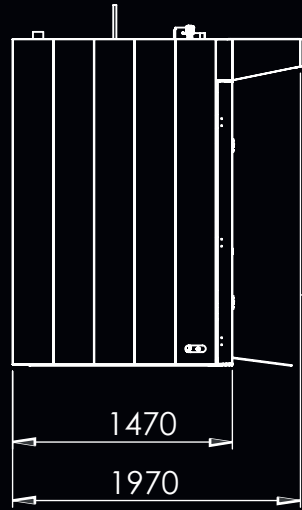
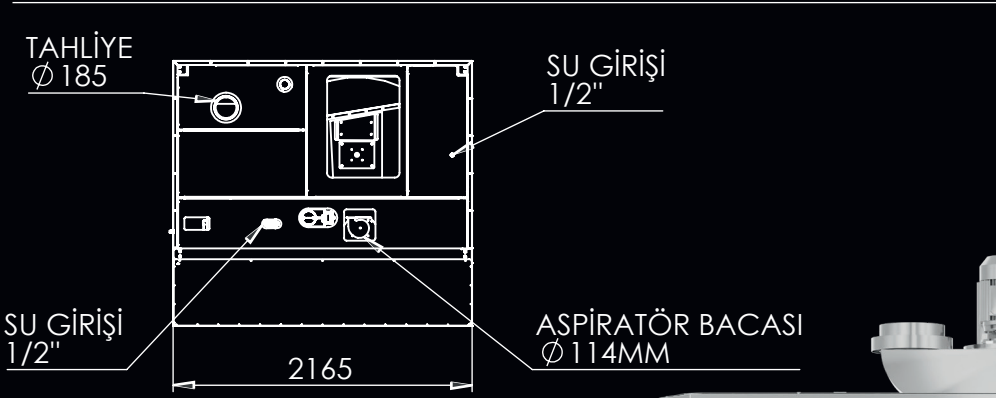

TOPLAM ELEKTRİK GÜCÜ; 3.5 kW

ATDFY 150

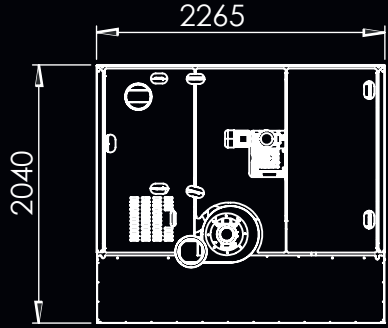

BUĞU FANI
BACA ÇAPI
(HOOR EXHAUST): \varnothing 196

ELEKTRİK GİRİŞİ
(ELECTRIC INLET): 380V

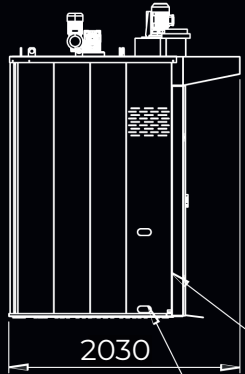
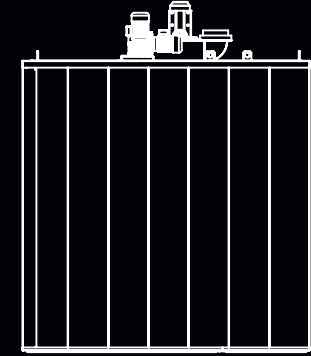

GAZ GİRİŞİ (GAS INLET): 3/4"

SU ÇIKIŞI (WATER EXIT): 1"

SU GİRİŞİ (WATER INLET): 1/2"

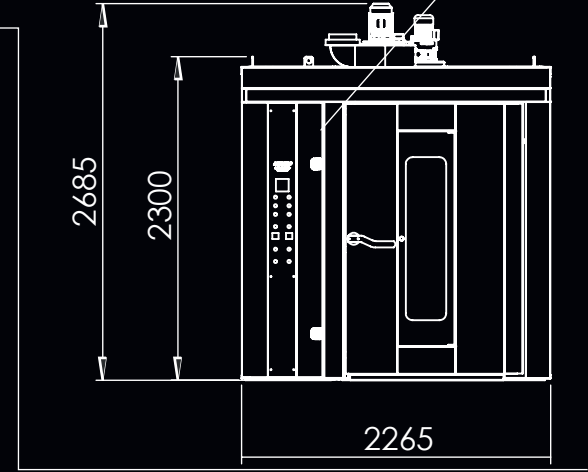

ELEKTRİK KABLOSU
(ELECTRIC CABLE)

4X1,5 - 2X0,75

TOPLAM ELEKTRİK
SARFIYATI (TOTAL
ELECTRIC POWER)

3.5 kW

ATDFY 300

